

MOTOR CONTROLLER SPECIFICATION

800S, 120/240V

1. Scope

This specification defines the characteristics for an 800S motor controller (120/240V), originally developed for laundry applications. This motor controller will run Fisher & Paykel Technologies motors using Sensorless Vector control and provides the features listed in this specification.

2. Motor Controller Operation

Control Features

- Spin control of speed, acceleration and direction.
- Agitation control with a profile defined by acceleration, plateau speed, plateau time and pause time.

Feedback Features

The controller can measure and report the following quantities during operation:

- Fault Registers –fault status of the controller and connected motor
- Inverter Bridge Temperature – the measured temperature of the power section of the controller
- DC-link bus voltage
- Instantaneous and Average motor current
- Motor status – what mode of operation the motor is currently in (Idle, Spinning, Agitation etc.)
- Motor Temperature –the estimated motor temperature using the built-in thermal model and motor winding resistance measurement during start-up.
- Motor Speed – the current motor speed in RPM.

3. Specification – Motor Controller

Functional Block Diagram

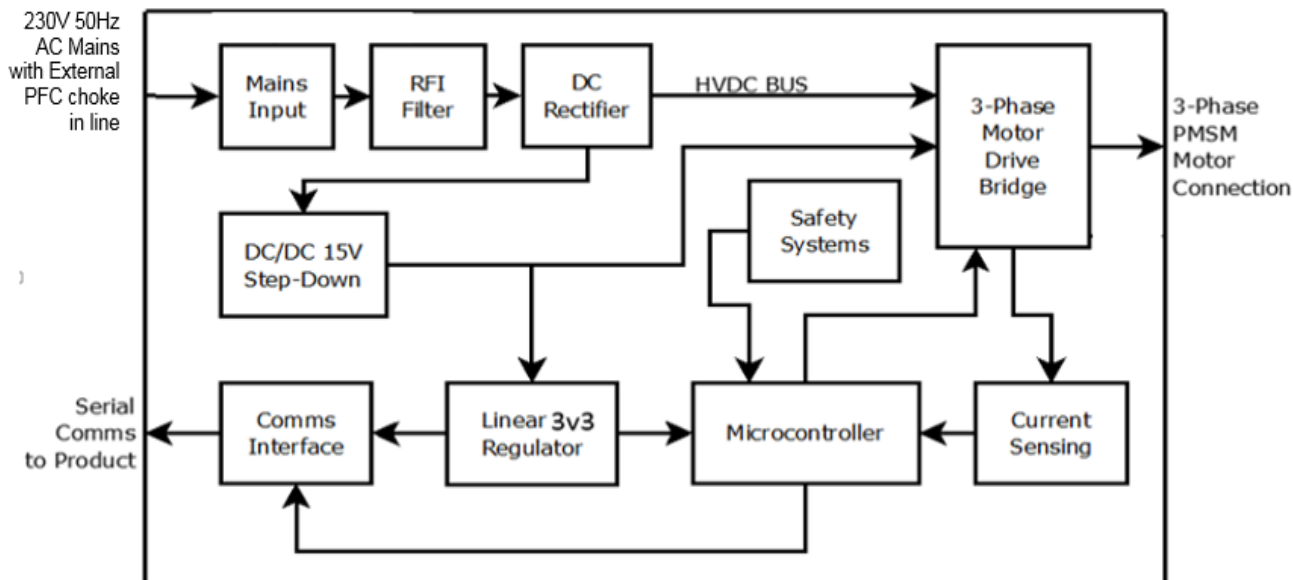

Functional block diagram of the Motor Control Module and external connections

Absolute Maximum Ratings

Use of the control outside of these maximum ratings may cause irreversible damage or improper operation of the controller.

Rating	Symbol	Minimum	Maximum	Units
Utility Mains Input Voltage	V_{MAINS}	187	264	V
RMS Motor Output Current (per motor phase)	I_{MOTOR}	-	3.45	A
Motor Output Power* ¹	$P_{\text{MOTOR(AV)}}$	-	800	W
Supply Voltage for Communications Interface	$V_{\text{CC(COMMS)}}$	9	12	V
Ambient Temperature of Surrounding Air	T_{AMB}	0	50	°C
Ambient Humidity of Surrounding Air * ²	RH_{AMB}	20	90	%RH

*1 – Averaged over a 10 second period

*2 – Ambient temperature and humidity conditions should be maintained such that condensation does not form on or inside the controller module

4. Connector Pin Description

Connector	Pin	Name	Function
Mains Input	1	EARTH	Earth connection to the RFI Filter (optional)
	2	NEUTRAL	Utility mains voltage input connection – Neutral line
	3	PHASE	Utility mains voltage input connection – Phase / Active line
Motor Connection	1	MTR_A_OUT	Output connections to the motor. It is important that these are connected in the correct polarity or the motor may not spin in the correct direction when driven
	2	MTR_C_OUT	
	3	MTR_B_OUT	
Isolated Comms	1	0V_isolated	0V reference connection for the isolated comms bus
	2	Rx/Tx_isolated	Serial communications signal
	3	External V_isolated	Power supply for the isolated comms bus. See section 'Absolute Maximum Ratings'
RPS & Motor TEMP connector	1	MOTOR_TEMP	Motor temperature / ID
	2	0V	0V
	3	+15V	15V supply
	4	RPS_A	RPS input to controller (Phase A)
	5	RPS_B	RPS input to controller (Phase B)
	6	RPS_C	RPS input to controller (Phase C)

Physical Dimensions

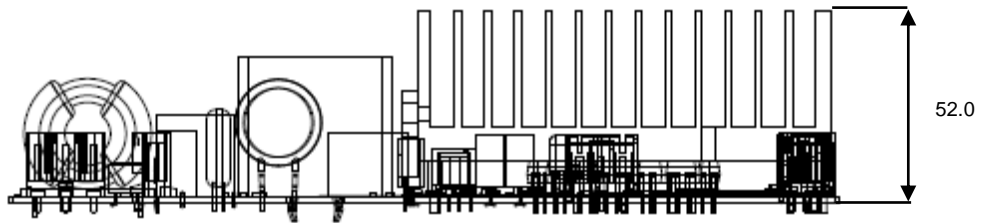
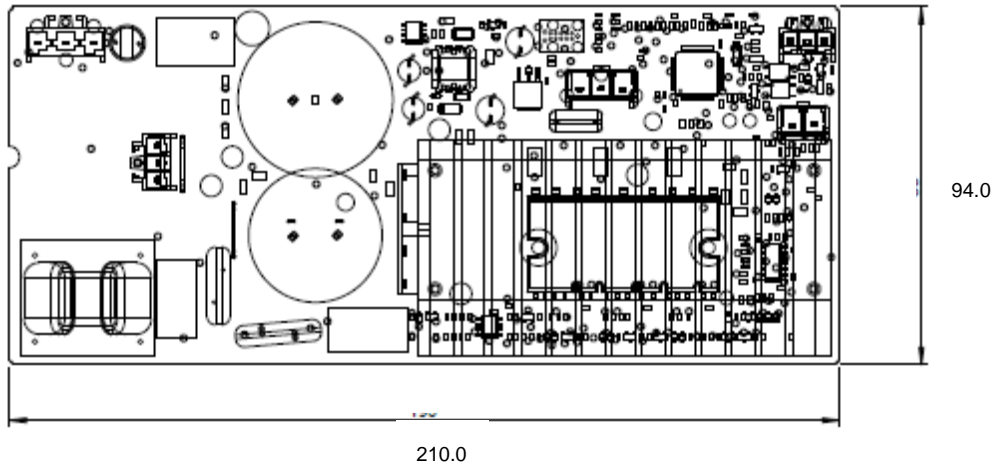

***All dimensions are in mm

Serial Communications Interface

The serial communications interface is implemented as a single-wire open-collector half-duplex serial communications link.

- Baud rate: auto select between 4800bps (for product comms)
- 8 Data bits
- No Parity
- 1 Stop bit.

The open-collector interface is non-inverting, NPN output with the open-collector pulling down to 0V. Nominal input/output impedance is 10KΩ.

4. Compliance and Standards

UL approval process is ongoing for the 800S motor controller.

Safety Functions

The following safety functions of the controller are declared as part of this evaluation:

- Locked-Rotor protection – detects the motor locked-rotor condition and prevents operation under this condition
- Loss-of-Phase protection – detects an open-circuit condition in any of the motor winding circuits and prevents operation under this condition
- Motor Winding Over-Temperature protection – uses a thermal model to prevent over-temperature conditions in the motor windings
- Automatic Restart – the minimum automatic recovery period after a fault condition is detected is guaranteed

Rating	Symbol	Minimum	Typical	Maximum	Units
Locked Rotor Detection Time	$t_{\text{DETECT(LR)}}$	5	-	10	s
Loss of Phase Detection Time	$t_{\text{DETECT(LOP)}}$	0.5	-	10	s
Motor Winding Temperature Limit	T_{OVERTEMP}	-	170	200	°C
Automatic Restart Time	t_{RESTART}	3	-	10	s